

# VYM-100

## GATE VALVE PN100 SÜRGÜLÜ VANA PN100

Design / Dizayn: EN 1171  
Face to Face / L Boyu: EN 558 Serie 26  
(DIN 3202 F7)  
Pressure Rate / Basınç Aralığı: PN100  
Size Range / Ölçü Aralığı: DN 50-DN 300  
Temperature / Sıcaklık: -20....+400 °C  
Flange Ends / Flanş: DIN EN 1092-1  
Test: DIN EN 12266

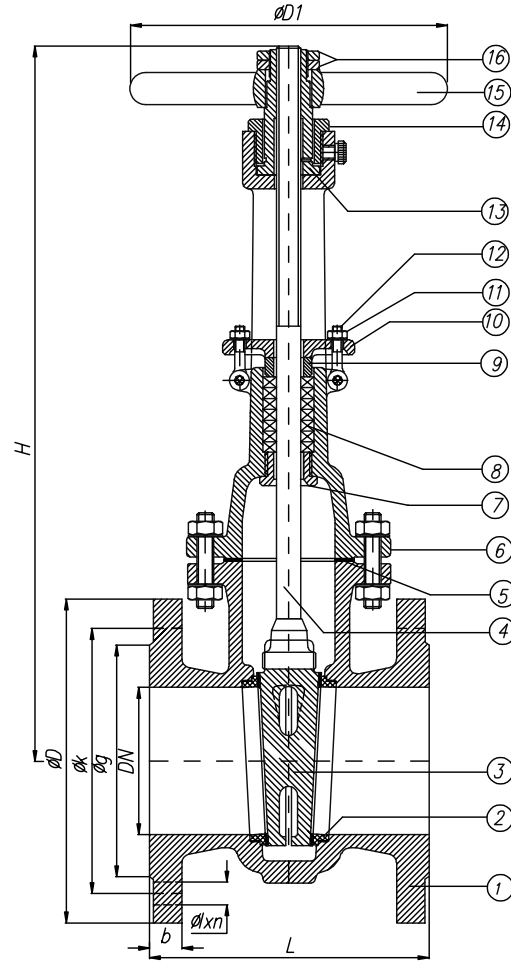

### DIN 2401 MALZEME VE SICAKLIK BAĞLANTI NORMATI

MATERIAL / MALZEME	TEMPERATURE / SICAKLIK °C					
G-SC 25 (GP 240GH+N)	-20° +120°	+200°	+250°	+300°	+350°	+400°
ASTM A Gr. A216 WCB	100 Bar	80 Bar	70 Bar	60 Bar	56 Bar	50 Bar

NO	PART NAME	PARÇA ADI	MATERIAL / MALZEME	NO	PART NAME	PARÇA ADI	MATERIAL / MALZEME
1	Body	Gövde	GS-C25(GP240GH)(1.0619)(A216 WCB)/ A217 WC6, WC9 / SS304 / SS316	9	Packing Nut	Salmastra Baskısı	GS-C25(GP240GH)(1.0619)(A216 WCB)/ A217 WC6, WC9 / SS304 / SS316
2	Seats	Burçlar	13Cr/Stellite 6, Stellite 12/SS304/SS316	10	Gland Flange	Baskısı Flanşı	GS-C25(GP240GH)(1.0619)(A216 WCB)/ A217 WC6, WC9 / SS304 / SS316
3	Wedge	Sürgü	GS-C25(GP240GH)(1.0619)(A216 WCB)/ A217 WC6, WC9 / SS304 / SS316	11	Stud	Saplama	Cr. Mo Alaşımli Çelik/Cr Mo Alloy Steel A193 Gr. B7
4	Stem	Mil	AISI420(X20Cr13)(A182 F6)SS304/SS316	12	Nut	Somun	Karbon Çeliği/Carbon Steel A194 Gr. 2H
5	Gasket	Conta	Graphite / Graphite + SS304	13	Yoke Nut	Mil Yatağı	Bronze
6	Bonnet	Kapak	GS-C25(GP240GH)(1.0619)(A216 WCB)/ A217 WC6, WC9 / SS304 / SS316	14	Centering Nut	Mil Yatağı Somunu	Bronze
7	Back Seat	Geri Ring	13Cr(X20Cr13)(A182 F6)SS304/SS316	15	Handwheel	Volan	Sfero Döküm / Ductile Iron
8	Packing	Salmastra	Graphite / PTFE	16	Handwheel Nut	Volan Somunu	SS420 / Bronze

Nominal Pressure / Anma Basıncı	PN	100									
Nominal Diameter / Anma Çapı	DN	50	65	80	100	125	150	200	250	300	
Valve Dimensions / Vana Boyutları DIN EN 558-1/26	L	250	290	310	350	400	450	550	650	750	
	H	490	540	575	675	745	800	890	1050	1200	
	ØM	250	250	310	415	500	500	600	720	720	
Flange Dimensions / Flanş Ölçüleri DIN EN 1092-1 PN100	ØD	195	220	230	265	315	355	430	515	585	
	Øk	145	170	180	210	250	290	360	430	500	
	Øg	102	122	138	162	188	218	285	345	410	
	b	30	34	36	40	40	44	52	60	68	
	Ø1xn	Ø22x4	Ø22x8	Ø22x8	Ø30x8	Ø33x8	Ø33x12	Ø36x12	Ø39x12	Ø42x16	
Weight / Ağırlık	kg	25	32	36	55	88	110	155	310	355	